

A NEW DISPERSIVE MIXER FOR SINGLE SCREW EXTRUDERS

*Chris Rauwendaal, Rauwendaal Extrusion Engineering, Inc.
Tim Osswald, University of Wisconsin, Madison
Paul Gramann and Bruce Davis, The Madison Group*

INTRODUCTION

Single screw extruders with simple conveying screws have poor mixing capability (1, 4). To improve the mixing capability mixing sections are often incorporated in the screw design. The most commonly used distributive mixing elements are pin mixers, slotted flight mixers, and cavity mixers. Commonly used dispersive mixing elements are blister rings and fluted mixing sections. Even though various dispersive mixing elements have been available since the 1960s, the dispersive mixing ability of single screw extruders is rather poor compared to twin screw compounding extruders. In this paper, we will examine the limitations of current dispersive mixers and introduce a new generation of dispersive mixers that will allow single screw extruders to match or better the dispersive mixing ability of twin screw extruders.

LIMITATIONS OF CURRENT DISPERSIVE MIXERS

Important requirements for dispersive mixing elements were formulated by Rauwendaal (2); they are:

- A. The mixing section should have a high stress region where the material is subjected to high stresses.
- B. The high stress region should be designed such that the exposure to high stresses occurs only for a short time.
- C. All fluid elements should experience the same high stress level for the same time to accomplish uniform mixing.

Based on these requirements many commercial dispersive mixers were compared and ranked. From analysis of mixing in twin screw extruders and internal mixers, other requirements for efficient dispersive mixing can be formulated that apply equally well to single screw extruders. These additional requirements are:

- D. The mixing section should be designed such that the fluid elements experience substantial elongational stresses in the high stress regions.
- E. All fluid elements should experience multiple passes through the high stress region to achieve a fine level of dispersion.

Also, requirement B should be amended as follows.

- B1. The high stress region should be designed such that the exposure to high shear stresses is short enough to avoid excessive screw power consumption and temperature rise in the polymer melt.
- B2. The high stress region should be designed such that the exposure to high elongational stresses is as long as possible to maximize the dispersive mixing action.

The most commonly used dispersive mixer in single screw extruders is the LeRoy mixer (3), popularized by Maddock. There are several versions of the fluted mixing section (2), the helical LeRoy being a popular mixing section due to its low pressure drop and good streamlining. If we analyze current dispersive mixers based on requirements A through C, then fluted mixers do a good job. However, when we add requirements D and E, then the current dispersive mixers do not meet these requirements.

Most current dispersive mixers rely on shear stresses to achieve breakdown of agglomerates. However, since elongational flow generates higher stresses, it is more effective in breaking down agglomerates. Therefore, it would be preferred to have strong elongational flow in the dispersive mixer. Also, in current dispersive mixers the material passes through the high stress region (HSR) only once; this severely limits the level of dispersion that can be achieved.

To achieve a fine level of dispersion it is generally necessary for the agglomerates or droplets to be broken down several times, which means that multiple passes through a high stress region are critical. A single pass through a high stress region

is not sufficient in most cases. If an agglomerate is of the order of 1000 μm and needs to be reduced to the 1 μm level, then it will take about 10 rupture events if we assume that each rupture event reduces the agglomerate size by 50 percent.

If each pass through a high stress region produces one rupture, then it becomes clear that a dispersive mixer that exposes the polymer melt to only one high stress exposure is not going to achieve a fine level of dispersion, in fact, far from it. This is an important reason why current dispersive mixers in single screw extruders do not work well. The lack of strong elongational flow and the lack of multiple passes through the HSRs explain why current dispersive mixers for single screw extruders have limited dispersive mixing capability.

NEW DISPERSIVE MIXERS FOR SINGLE SCREW EXTRUDERS

With the requirements formulated above, new geometries have been developed that substantially improve dispersive mixing; a patent application for this new dispersive mixing technology is pending. As stated earlier, the key to the enhanced mixing efficiency is the generation of elongational flow in the high stress regions and achieving multiple passes of all fluid elements through the HSRs.

Elongational flow is not easily achieved in screw extruders. It can be generated most efficiently by modifying the leading flight flanks of a mixing section such that the space between the flank and the barrel becomes wedge shaped. This can be done by either slanting the leading flight flank or by using a curved flight flank geometry as shown in figure 1. Multiple passes through the HSRs can be achieved by using a multi-flighted geometry. A possible geometry is shown in figure 2.

In order to achieve multiple passes through the HSRs, they should be designed such that significant flow takes place through them. This issue was studied by Tadmor and Manas-Zloczower (4). Substantial flow through the HSR can be achieved by increasing the flight clearance. However, that will only work partially because without randomization of the polymer melt, increasing the flight clearance will only result in mixing of the outer recirculating region (1). Another problem with a large flight clearance is that it leaves a thick stagnant layer of polymer melt on the barrel surface. This problem can be circumvented by using at least one wiping flight in addition to the mixing flights. A possible mixer geometry is shown in figure 3.

By intentionally incorporating distributive mixing in the dispersive mixer, randomization of the fluid elements can be achieved. This gives each fluid element equal chance to experience the dispersive lobal mixing action. Without this, only fluid elements in the outer recirculating region (shell) would participate in the dispersive mixing process (1). The slotted geometry shown in figures 2 and 3 has proven to be quite effective for distributive mixing (2).

The helix angle of the mixing flights can be positive, negative, and even zero. It is possible to use elements with 90° helix angle and stagger the elements to achieve forward or rearward conveying, similar to kneading blocks in co-rotating twin screw extruders. The difference is that the dispersion disks can be designed to achieve maximum dispersion without the geometric constraints associated with self-wiping action (1). An example of a collection of staggered dispersion disks is shown in figure 4.

The mixer has to be designed such that all fluid elements are exposed to a minimum number of passes through the high stress region. This requires a high enough flow rate through the high stress regions and efficient distributive mixing. Determination of the appropriate clearance of the mixing flights is discussed in the next section.

DETERMINING THE PROPER CLEARANCE VALUE

According to Tadmor and Manas-Zloczower (4) the passage distribution function can be written as:

$$G_k = \frac{I^k e^{-I}}{k!} \quad (1)$$

where k is the number of passes through the clearance, the dimensionless time $I = t_r / \bar{t}$ is the ratio of the residence time t_r and the mean residence time of the controlled volume \bar{t} . The residence time for a Newtonian fluid can be approximated as follows:

$$t_r = \frac{2z}{v_{bz}(1-r)} \quad (2)$$

where z is the helical length of the screw section considered, v_{bz} the down-channel barrel velocity, and r the throttle ratio (pressure flow rate divided by drag flow rate). The mean residence time can be determined from:

$$\bar{t} = \frac{2WH}{d_{bx} \left(1 + \frac{W}{w_f} \frac{d^2}{H^2} \right)} \quad (3)$$

where W is the channel width, H the channel depth, δ the radial flight clearance, and w_f the flight width. The dimensionless time can be written as:

$$I = \frac{Ld \left(1 + \frac{W}{w_f} \frac{d^2}{H^2} \right)}{WH(1-r)\cos j} \quad (4)$$

where L is the axial length corresponding to down-channel distance z . The fraction of the fluid experiencing zero passes through the clearance is:

$$G_0 = e^{-I} \quad (5)$$

The G_0 fraction should be low to make sure that most of the fluid experiences at least one or more passes through the clearance. In a simple conveying screw the G_0 fraction is usually around 0.99, which means that most of the fluid passes through the extruder without ever passing through the clearance. We can use the expressions above to determine the minimum λ value that will yield a G_0 less than 0.01, meaning that less than one percent of the fluid will not pass through the clearance at all. This is achieved when the dimensionless time $\lambda > 4.6$. For certain values of L , H , W , r , ϕ , w_f we can then determine how large the flight clearance δ has to be to make $\lambda > 4.6$ or $G_0 < 0.01$.

When $L=3W$, $r=0$, and $\phi=17.67^\circ$, the ratio of δ/H has to be about 0.8 to achieve a $G_0 < 0.01$. Clearly, with such a high ratio of δ/H it will be almost impossible to create large stresses in the clearance and to accomplish effective dispersive mixing. From equation 4 it is clear what geometrical variables we have to change to achieve a low G_0 fraction at a small clearance. We can do this by 1) increasing L , the length of the mixing section, 2) increasing ϕ , the helix angle, and 3) reducing w_f , the width of the flight.

If we increase the helix angle from 17.67 to 60 degrees with the other values being the same, the δ/H ratio has to be about 0.35 or greater for the G_0 fraction to be less than 0.01. This value is still rather larger, but substantially better than 0.8. The δ/H ratio can be further reduced by increasing the length of the mixing section or reducing the flight width or by increasing the helix angle even more. The point is that this procedure allows a first order determination of the design variables. Further refinement of the initial values can be obtained from computer simulation.

COMPUTER SIMULATION

The analytical approach to mixer design has some severe limitations because it is very difficult to analyze flow in a complicated mixer geometry. A better approach to analyze complicated mixers is to use mathematical modeling and computer simulation. One simulation tool that lends itself well to the analysis of complicated mixer geometries is the boundary element method (BEM). This method allows a determination of the optimum value of the flight clearance, flight flank geometry, and spacing of the slots to achieve the proper combination of dispersive and distributive mixing action. Recently, a three dimensional BEM package was developed at the University of Wisconsin in Madison (5) and commercialized by the Madison Group (6).

To help determine the flight flank geometry and clearance, a two-dimensional BEM analysis was initially performed. To quantitatively analyze the section, the flow number (7) was used and is given as:

$$C = \frac{\dot{\boldsymbol{\epsilon}}}{\dot{\boldsymbol{g}} + \boldsymbol{W}} \quad (6)$$

Here, $\dot{\boldsymbol{\epsilon}}$ is the magnitude of the rate of deformation tensor and \boldsymbol{W} the magnitude of the vorticity tensor. Where, $C=1.0$ signifies pure elongational flow, $C=0.5$ simple shear flow, and $C=0.0$ pure rotational flow.

To determine the mixing capability of a system the forces that the mixer can apply are of extreme importance. In simple shear flow, the force that is applied is given by (8):

$$F_{shear} = 3\boldsymbol{h}_s \dot{\boldsymbol{g}}^2 \quad (7)$$

and for pure elongational flow:

$$F_{elongation} = 6\boldsymbol{h}_e \dot{\boldsymbol{g}}^2 \quad (8)$$

where, \boldsymbol{h}_s is shear viscosity of the carrier fluid, \boldsymbol{h}_e the elongational viscosity, and r the radii of particles to be broken up. Considering that the elongational viscosity is usually three times the shear viscosity, the equations above indicate that elongational flow can generate substantially higher stresses than shear flow.

Using the BEM simulation, the flow number and forces at any point in the mixer can be computed. Moreover, particles can be tracked through the mixer to determine streamlines and detect possible stagnant regions. Figure 5 shows the calculated streamlines in the proposed mixing section. Here, at every time step, the strain rates and flow numbers are calculated. Figure 6 shows the flow number of a particle as it flows through the system. Flow numbers are achieved as high as 0.95, indicating that strong elongational flow can be generated in the new mixers. Similarly, figure 7 shows the magnitude of the rate of deformation tensor of the particle as it flows through the system. As the particle approaches the flight, it “feels” an increase in the elongational flow. While passing over the top of the flight, the elongational flow switches to shear flow, but at the same time the magnitude of the rate of deformation tensor increases. This effect will increase the mixing capability of the system.

One of the goals of this mixing section is to provide improved distributive mixing as well as dispersive mixing. Introducing grooves in the modified flight will increase the distributive mixing and at the same time allow the recirculation areas shown in figure 5 to be broken up. To calculate the splitting of the material (distributive mixing effect) as it flows through the mixer a 3-dimensional BEM analysis was performed. Figure 8 shows how a grouping of particles flow through a region of the mixer. As expected, some particles flow over the modified flight while others flow through the groove. Again, this effect will increase the distributive and dispersive mixing capability of the mixer.

CONCLUSIONS

The new mixer technology described here allows single screw extruders to achieve dispersive mixing as good as that of intermeshing twin screw extruders. This finding runs counter to traditional thinking about mixing in single screw extruders

(9). The new mixer technology will allow single screw extruders to be used in applications where thus far only twin screw extruders could be considered. Thus, the use of single screw extruders can potentially be broadened significantly. Results of experimental studies will be presented in Atlanta confirming the theoretical results presented in this paper.

The new mixer geometries can improve mixing not only in single screw extruders, but also in non-intermeshing twin screw extruders. Current tangential extruders have limited dispersive mixing capability. Using the new mixer technology may allow these extruders to compete effectively with intermeshing twin screw extruders in applications where dispersive mixing is required; again, expanding the potential uses of these machines.

The boundary element method is a useful tool in the development and design of mixing sections with complex geometry. The BEM results of the new mixers indicate that strong elongational flow can indeed be generated by the wedge shaped geometry of the mixing flights. Also, multiple passes through the HSRs can be achieved, provided that the mixing flight clearance is properly dimensioned.

REFERENCES

1. C. Rauwendaal, "Polymer Mixing, A Self-Study Guide," Hanser, Cincinnati, OH (1997)
2. C. Rauwendaal in "Mixing and Compounding of Polymers, Theory and Practice," I. Manas-Zloczower and Z. Tadmor, Editors, Hanser, Cincinnati, OH (1994)
3. G. LeRoy, US Patent 3,486,192
4. Z. Tadmor and I. Manas-Zloczower, *Advances in Polymer Technology*, V.3, No.3, 213-221 (1983)
5. P.J. Gramann, L. Stradins, and T.A. Osswald, *Int. Polym. Proc.* 8, 287 (1993)
6. BEMflow, Boundary Element Fluid and Heat Transfer Simulation Program, ©1996 The Madison Group: PPRC
7. J. Cheng and I. Manas-Zloczower, *Polym. Eng. Sci.*, 29, 11 (1989)
8. Z. Tadmor, *Ind. Eng. Fundam.*, 15, 346 (1976)
9. M. Gale, "Compounding in Single-Screw Extruders," *Advances in Polymer Technology*, V. 16, N. 4, 251-262 (1997)

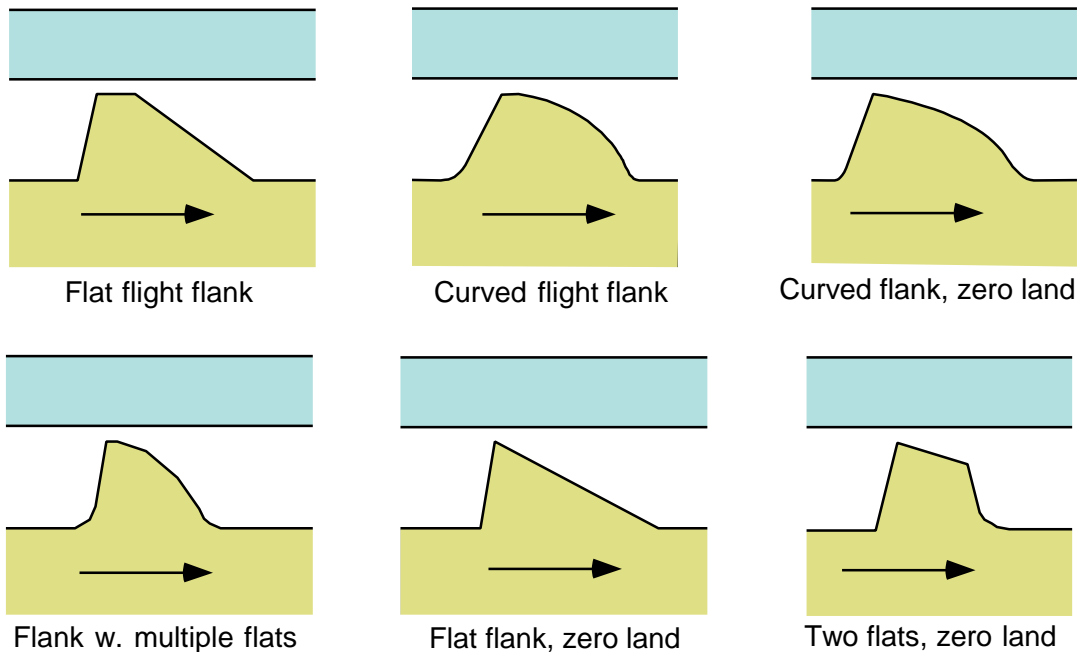

Figure 1, Flight geometries to create elongational flow

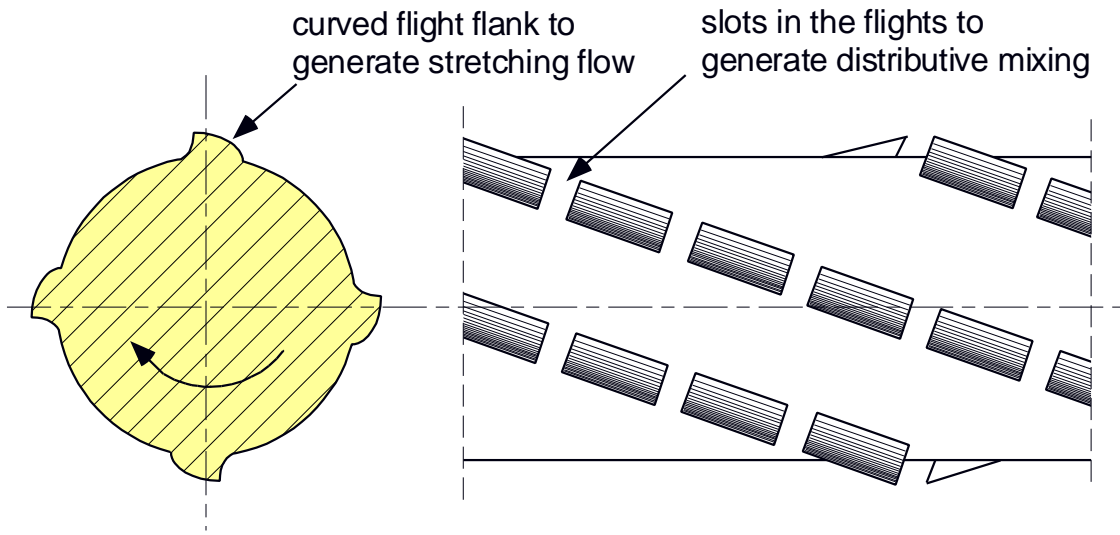

Figure 2, A helical, multi-flighted, dispersive/distributive mixer

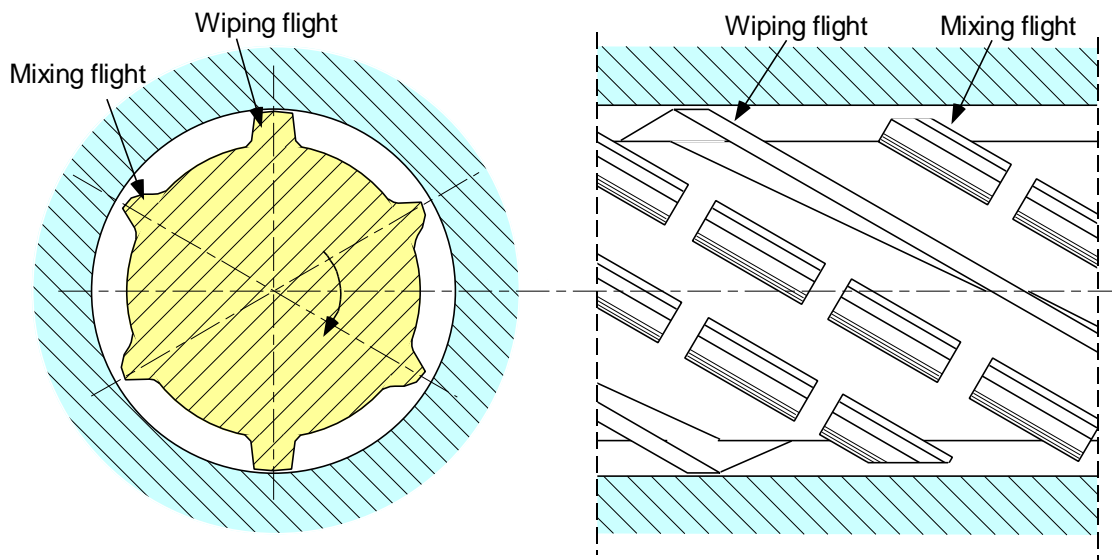

Figure 3, A multi-flighted mixer with mixing and wiping flights

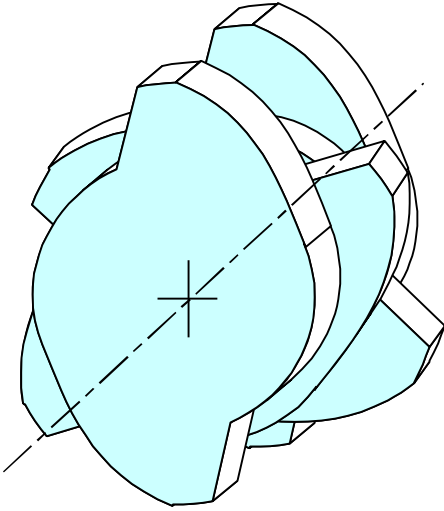

Figure 4, Staggered dispersion disks

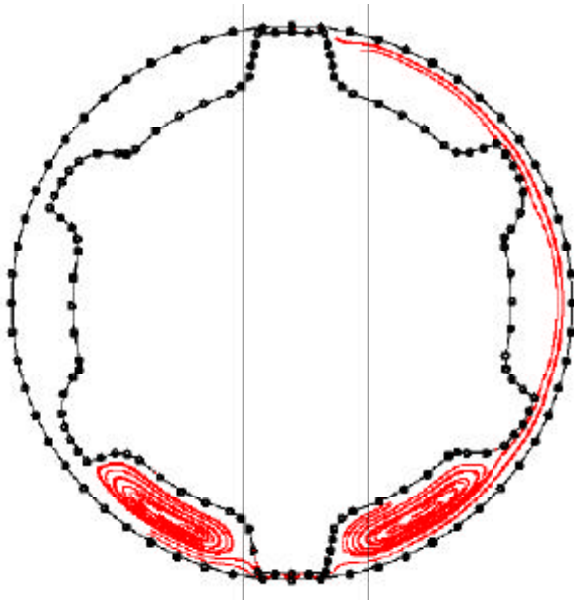

Figure 5, Predicted streamlines in mixer shown in figure 3

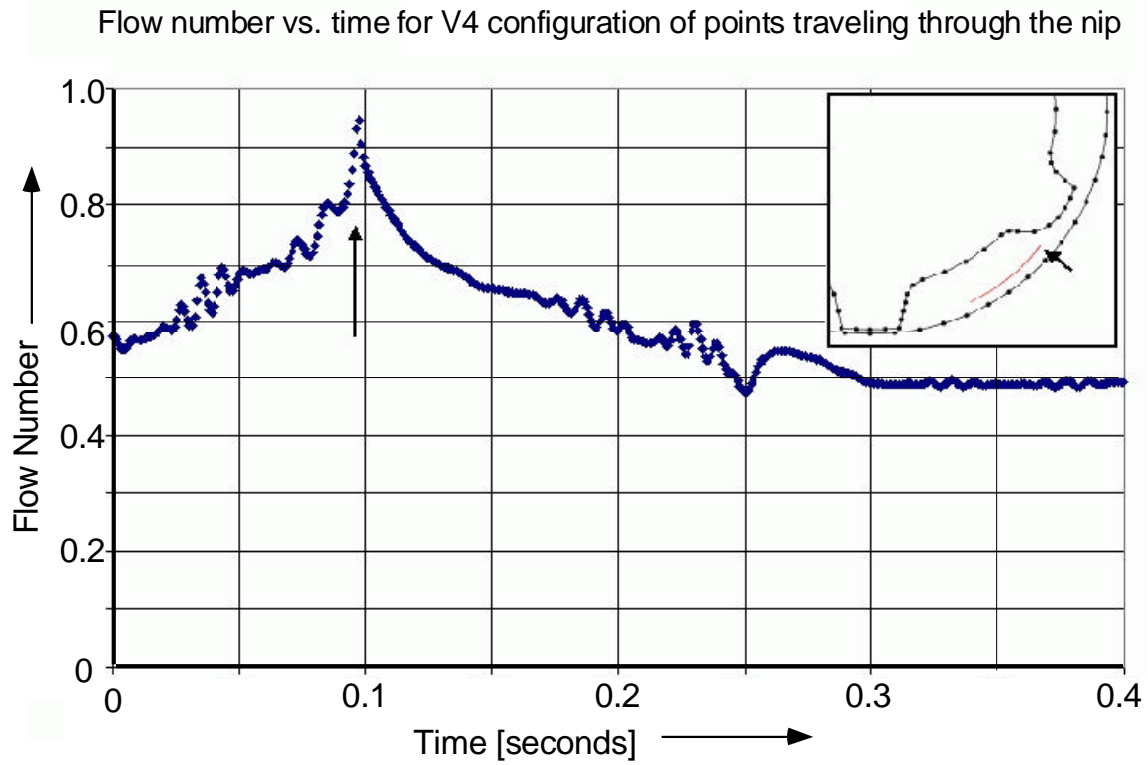

Figure 6, Flow number versus time for a point traveling through the nip region of the mixer shown in figure 3

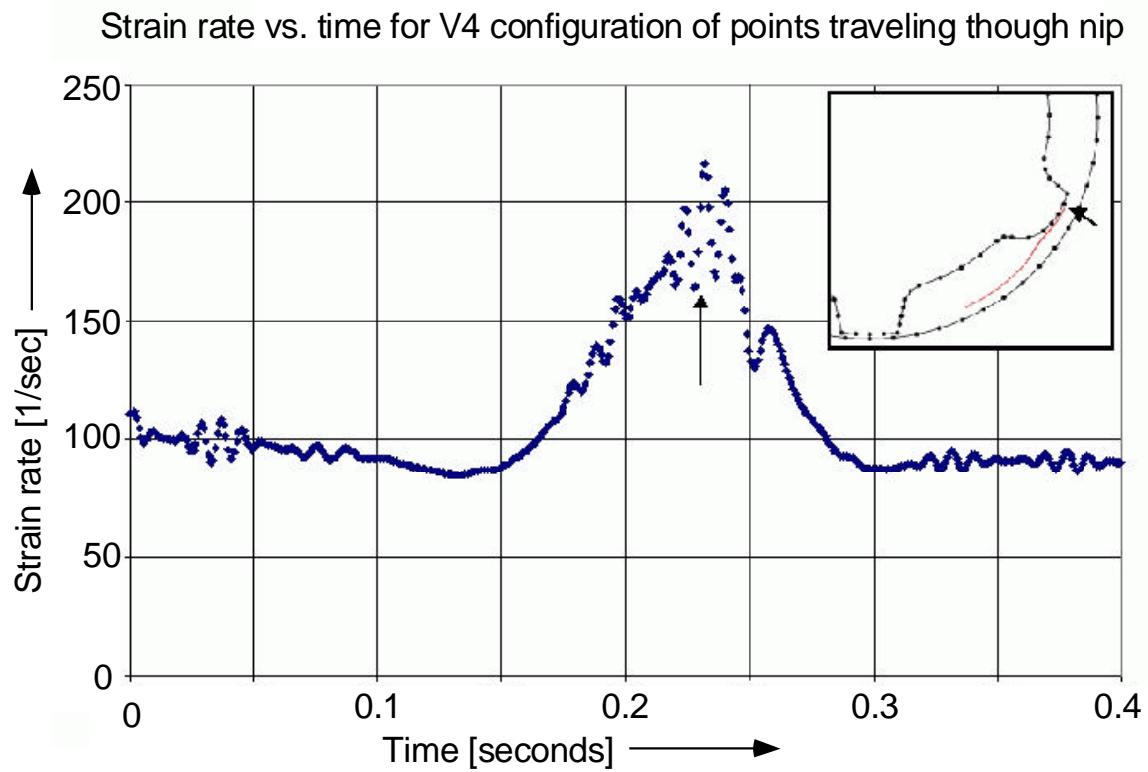

Figure 7, Strain rate versus time for points traveling through the nip

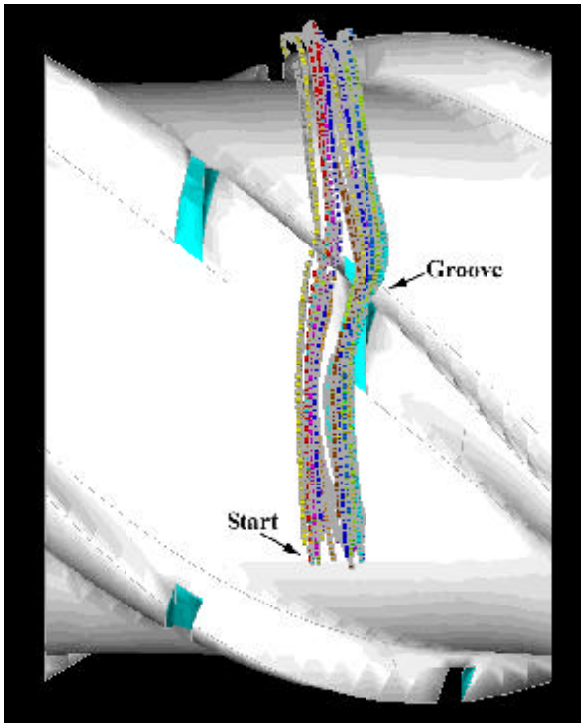

Figure 8, Tracking of multiple points in 3D simulation